

WATERMIST TECHNOLOGY (WMS[®]) FOR STAINLESS STEEL AND ALUMINIUM

- ▶ Up to 3 times faster cut speeds on 20 mm stainless steel compared to other plasma systems
- ▶ Similar quality to water-jet for the same cost as oxy-fuel Cutting
- ▶ Gas costs reduced to the minimum - using nitrogen as the plasma gas and ordinary tap water as the shield



We Bring Intelligence to the Table.™

WATERMIST TECHNOLOGY (WMS®)

WMS delivers excellent non-ferrous cut quality and low cost of operation by using N2 as plasma gas and ordinary tap water as the secondary. A reducing atmosphere is produced in the cut by the release of hydrogen from the secondary water.

Effect of N2/H2O Plasma on Non-Ferrous metals

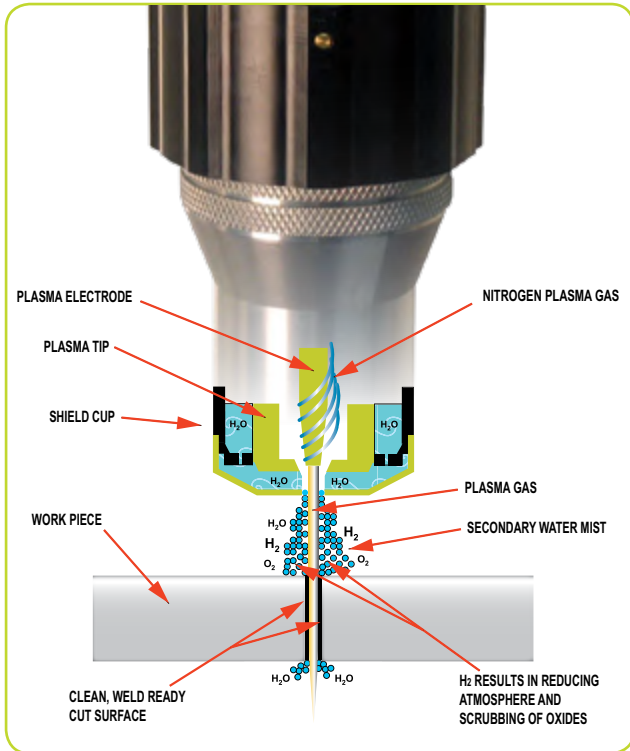

Example of a 20mm cut with WMS



By using N₂/H₂O instead of H₃₅/N₂ gas, the expense of gas is reduced, cut speed is increased, and distortion and the heat-affected zone are minimized. The result is a clean, dross-free and oxide-free cut surface that's ready to weld, form and paint. How does Water Mist Secondary technology work? During the cutting process, the water in the shield stream is divided into its principal components—hydrogen and oxygen. The hydrogen creates a reduced atmosphere in the cut zone, isolating it from contaminants at a much lower cost per metre than other cutting processes. Since it uses normal tap water, Water Mist Secondary also reduces production costs and keeps overall energy usage to a minimum. WMS technology is recommended for non-ferrous cutting up to 40 mm.

Advantages of WMS Technology

- Lowest operating cost.
- Cut speeds up to 3 times higher compared to H35 cutting.
- Dross-free cutting from 1 mm to 40 mm.
- Oxide-free cut face surface.
- Wide parameter window makes it easy to obtain the best results
- Operator-friendly
- Cut quality on aluminium is comparable to laser
- Small heat-affected zone and less distortion
- Cut surface is ready to weld

Stainless Steel Cut Speed Comparison

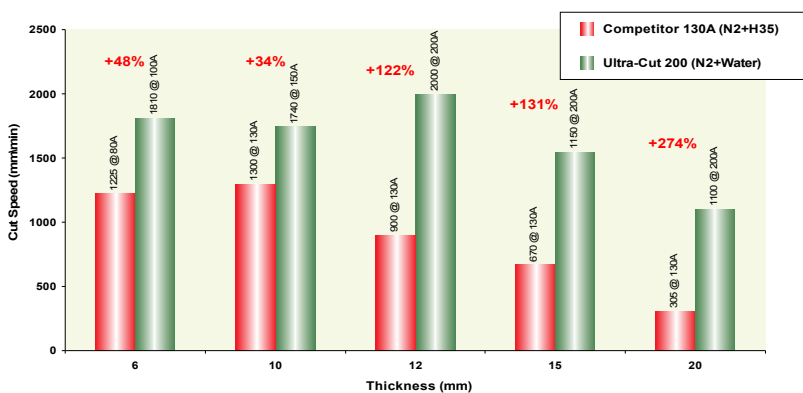

UK: Chorley North Industrial Park • Chorley, Lancashire PR6 7BX United Kingdom. Tel: +44 1257 224824 • Fax: +44 1257 224800
 ITALY: Via Benaco 3, 20098 San Giuliano Milanese (MI) Italy. Tel: +39 02 36546801 • Fax: +39 02 36546840
 GERMANY: Dierdorfer Straße 499 D-56566 • Neuwied-Gladbach Germany. Tel : +49 (0) 2631 999960 • Fax: +49 (0) 2631 9999610

www.thermal-dynamics.com Email: automation@thermal-dynamics.com

**THERMAL
DYNAMICS**